



Installation Guide for PermaSnap Premier Plus Coping

4 COMMERCE WAY, ARDEN, NC 28704 USA
800-892-9173 828-676-1700
OMGEDGESYSTEMS.COM



PermaSnap® Premier Plus Coping Reference Guide

1.	Standard Installation Steps	Page 3
1.1.	Corner Supports	Page 3
1.2.	Coping Clip	Page 3
1.3.	Coping Splice	Page 4
1.4.	Coping Miter	Page 4
1.5.	Coping End Condition	Page 5
1.6.	Coping Straight Section	Page 5
2.	Accessory Condition Guide	Page 6
2.1.	Inline Miter Conditions	Page 7
2.2.	Pier Miter Conditions	Page 8
2.3.	Tee Miter Conditions	Page 9
2.4.	Ridge Miter Conditions	Page 10
2.5.	Valley Miter Conditions	Page 10
2.6.	Horizontal Zee Miter Conditions	Page 11
2.7.	Vertical Zee Miter Conditions	Page 12
2.8.	Vaulted Conditions	Page 13
2.9.	Radius Conditions	Page 14

STEP 1: BEGIN COPING INSTALLATION AT CORNER LOCATIONS AS SHOWN IN PICTURE BELOW BY INSTALLING CORNER SUPPORTS FLUSH AGAINST THE SUBSTRATE THEN USING #14 X 1-1/2" UNIVERSAL FASTENERS FOR SECUREMENT.

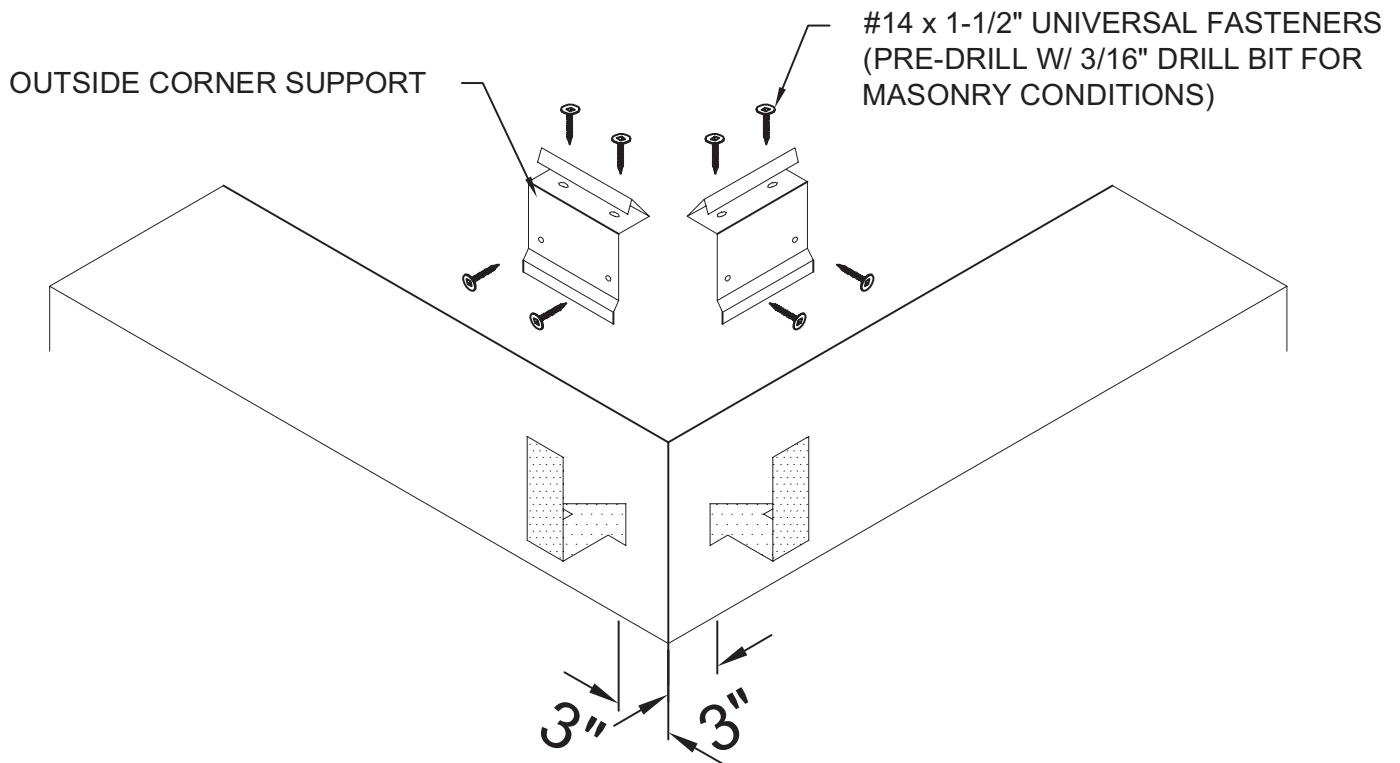

STEP 2: ALIGN CENTER OF EACH CLIP FROM THE CORNER SUCH THAT THE MITER LEG SITS DIRECTLY HALF-WAY OVER EACH CLIP AS SEEN IN STEPS 3 & 4 (PAGE 4)

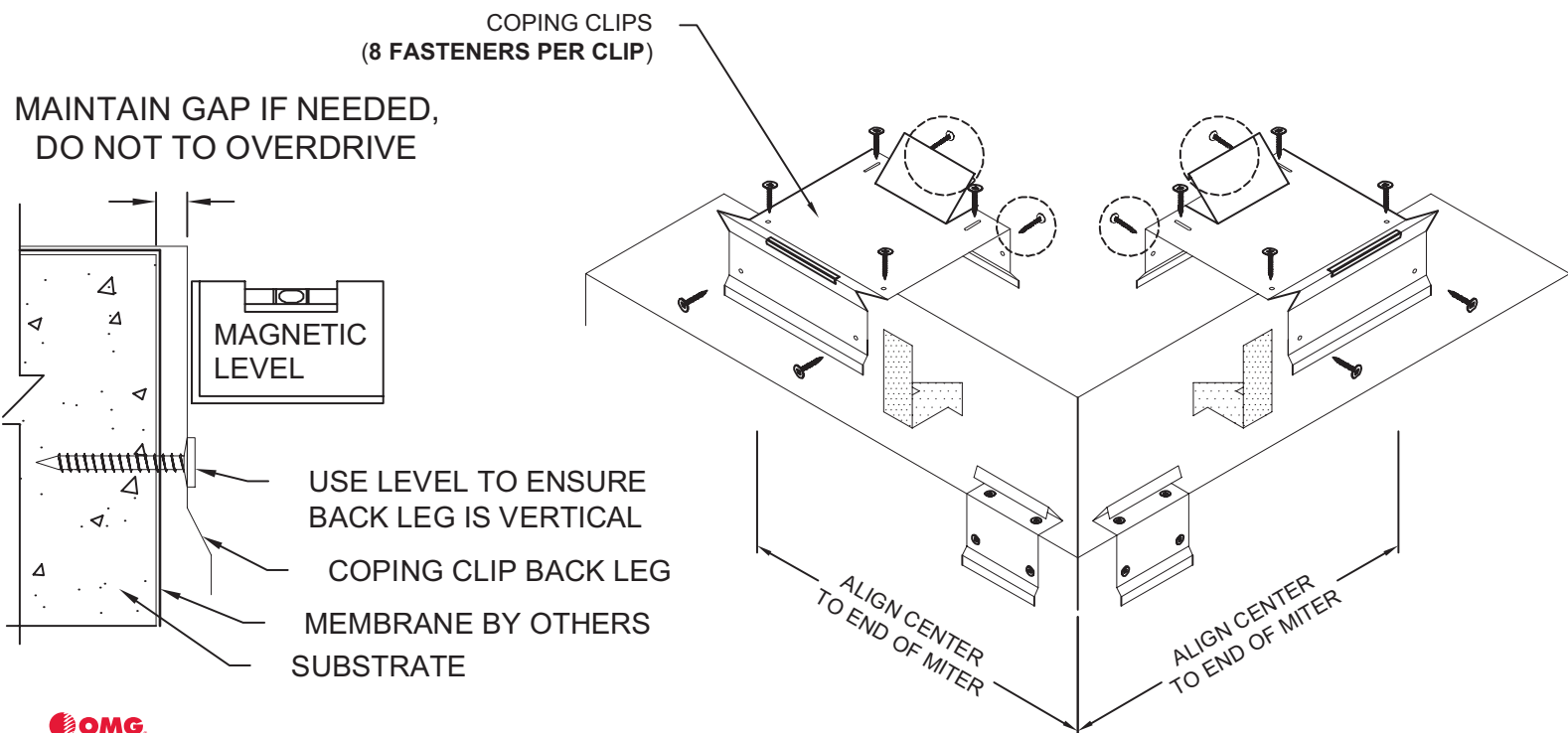

STEP 3: LOCATE SPLICES ONTO EACH CLIP, BEING SURE TO REMOVE TAPE FILM FROM EACH CLIP PRIOR TO PLACEMENT.

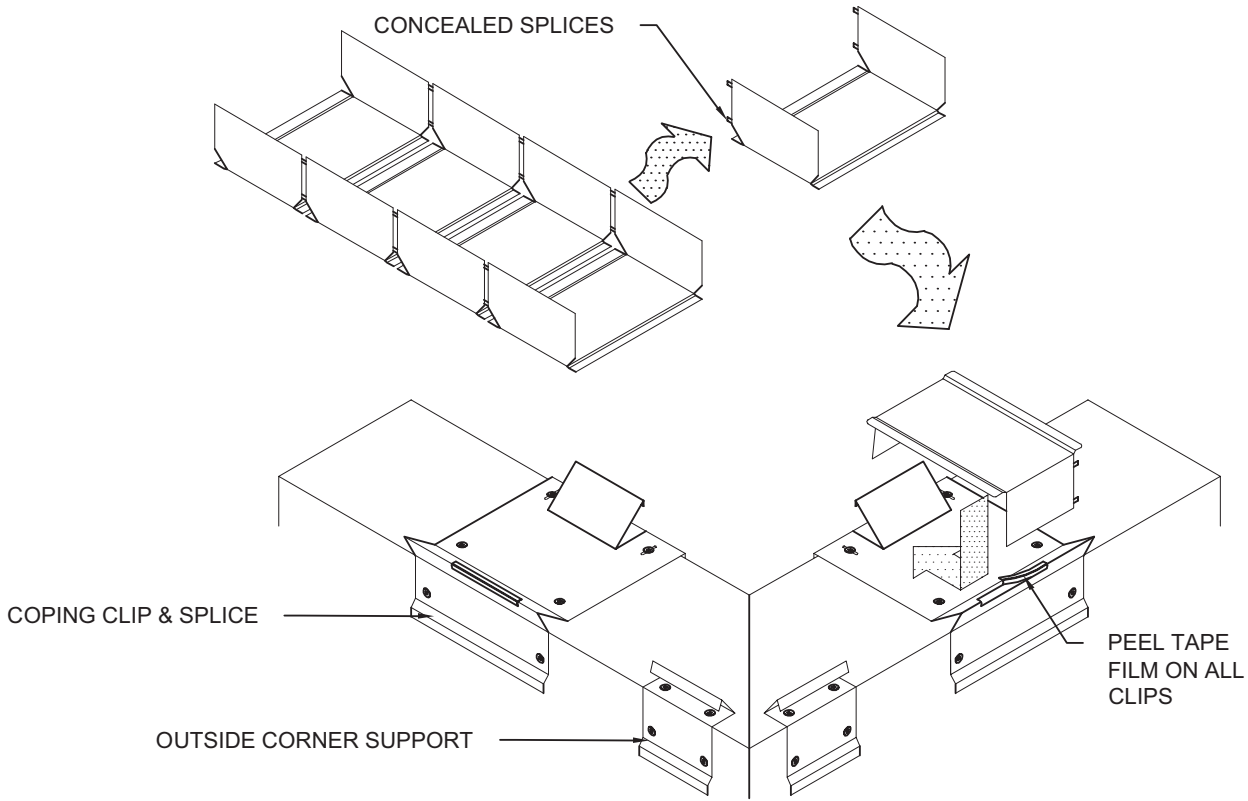

STEP 4: LOCATE MITER AND PLACE ONE LEG OVER THE CORNER SUPPORT AND CLIP, ROTATE BACKWARD AND PRESS DOWNWARD TO ENGAGE ONTO CLIP, THEN REPEAT ON ADJACENT LEG OF MITER.

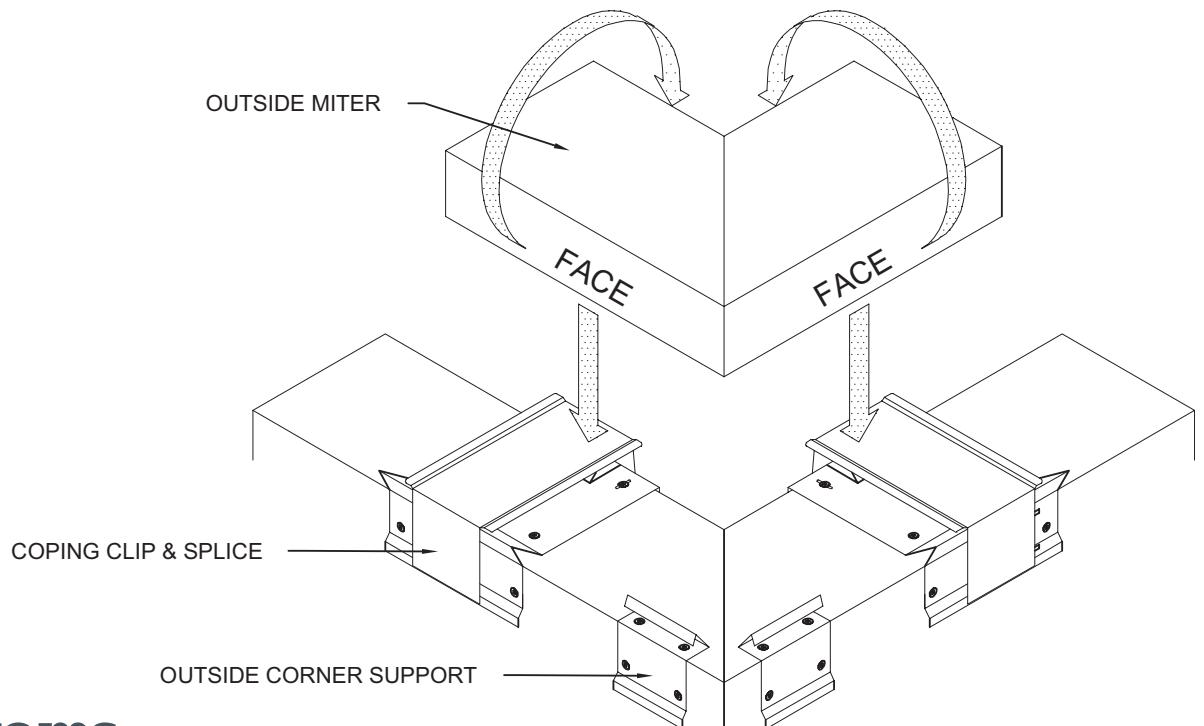

STEP 5: PLACE CLIPS AT END LOCATIONS SHOWN BELOW AND LOCATE END CAPS/END TERMS AND HOOK ON FRONT OF CLIP, ROTATE BACKWARD AND PRESS DOWNWARD TO ENGAGE ONTO CLIP.

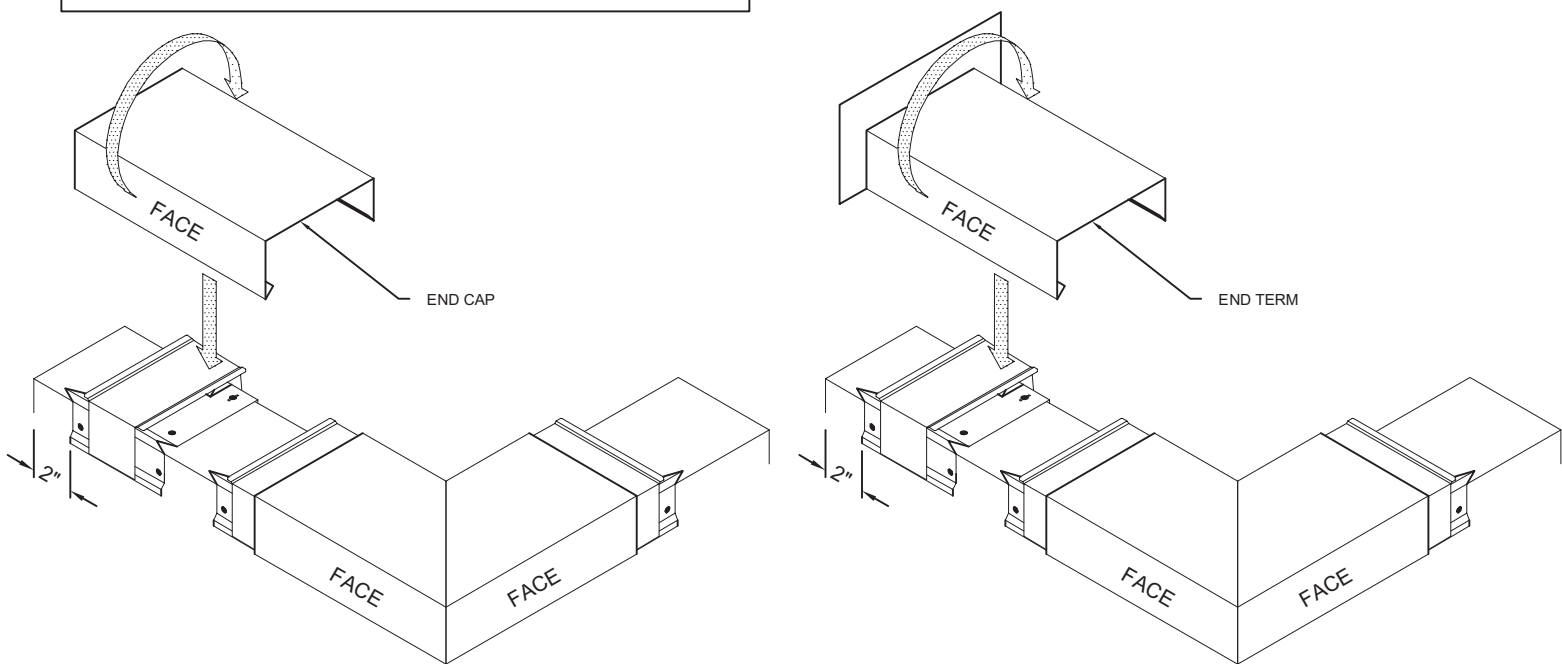

NOTE: ALL MITERS, END CONDITIONS, AND ACCESSORY CONDITIONS SHOULD BE INSTALLED PRIOR TO STRAIGHT SECTIONS

STEP 6: AFTER ALL CORNER AND END CONDITIONS ARE INSTALLED, USE TABLE BELOW TO INSTALL STRAIGHT SECTIONS, CUTTING DOWN AND ADJUST SPACING AS NEEDED. (DO NOT CUT CORNERS AND END CONDITIONS, USE STRAIGHT SECTIONS FOR ADJUSTMENTS.)

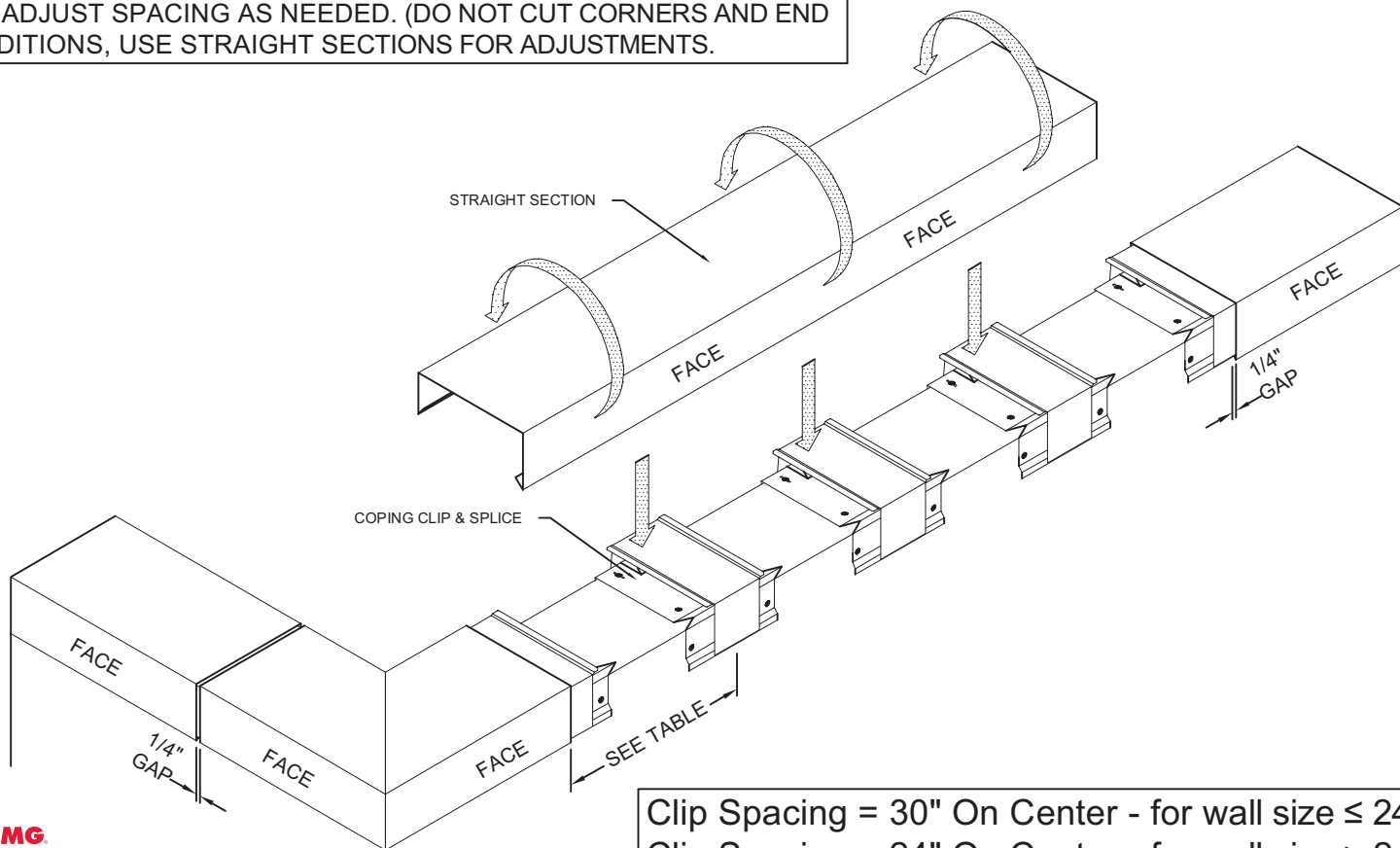

Clip Spacing = 30" On Center - for wall size \leq 24"
 Clip Spacing = 24" On Center - for wall size $>$ 24"



PermaSnap® Premier Plus Coping Accessory Conditions Reference

- Inline Miter Conditions (Page 7)
- Pier Miter Conditions (Page 8)
- Tee Miter Conditions (Page 9)
- Ridge Miter Conditions (Page 10)
- Valley Miter Conditions (Page 10)
- Horizontal Zee Miter Conditions (Page 11)
- Vertical Zee Miter Conditions (Page 12)
- Vaulted Conditions (Page 13)
- Radius Conditions (Page 14)

INLINE MITER CONDITIONS

AFTER INSTALLING MITER AND END LOCATIONS, CONTINUE INSTALLATION AT TRANSITION SECTIONS FIRST, BEING SURE CLIPS ARE LOCATED AT JOINTS AND SPACED ACCORDING TO THE CHART IN STEP 6. THEN CONTINUE TO INSTALL STRAIGHT SECTIONS.

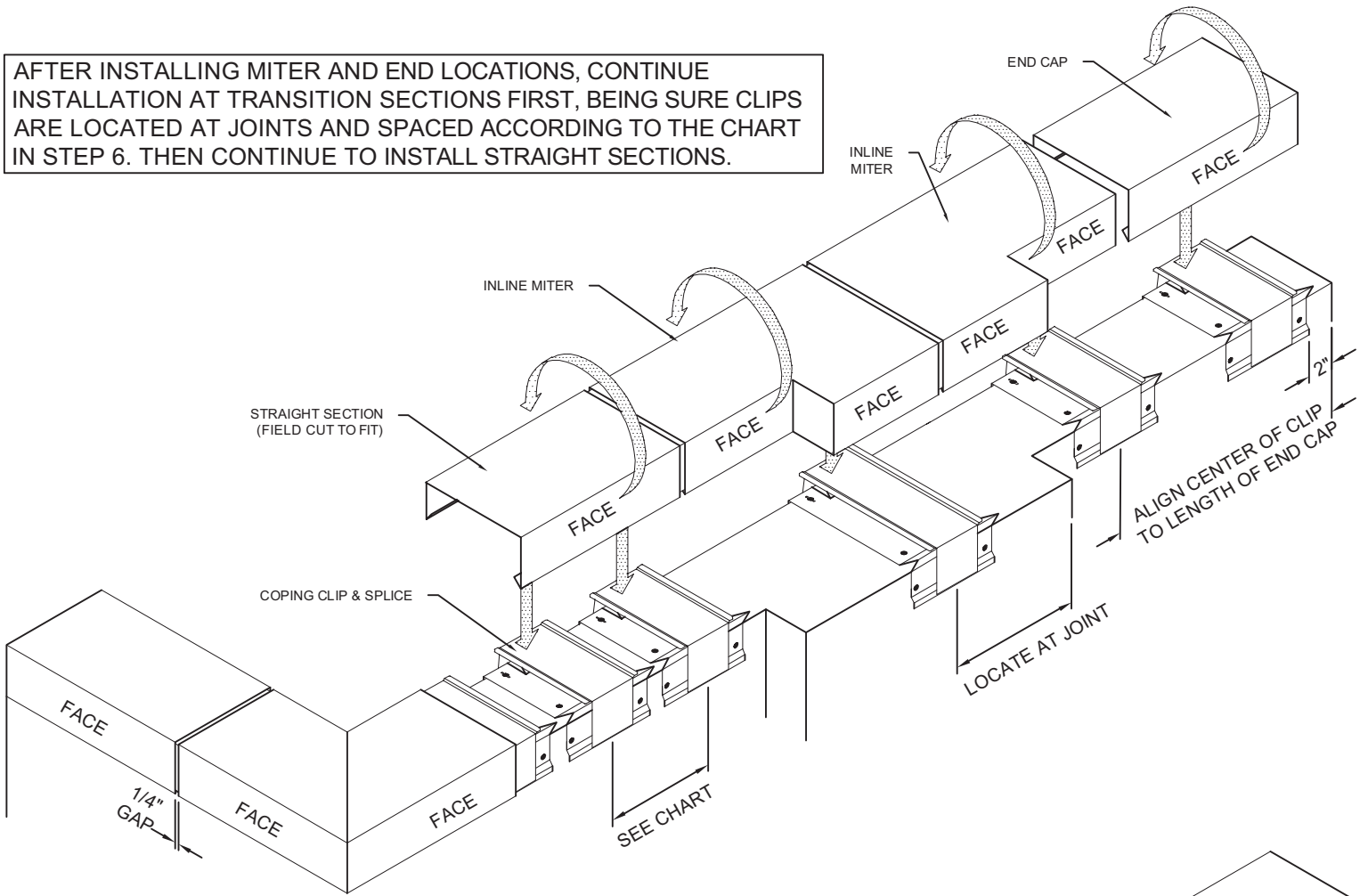

AFTER HOOKING COMPONENTS ONTO CLIP SECTIONS AND ROTATING BACKWARDS TO SNAP ONTO CLIP, USE GAP TOOL TO ENSURE ALL JOINTS ARE A MINIMUM OF 1/4" AND THAT ALL SCRATCHES ARE COVERED UP USING TOUCH-UP PAINT.

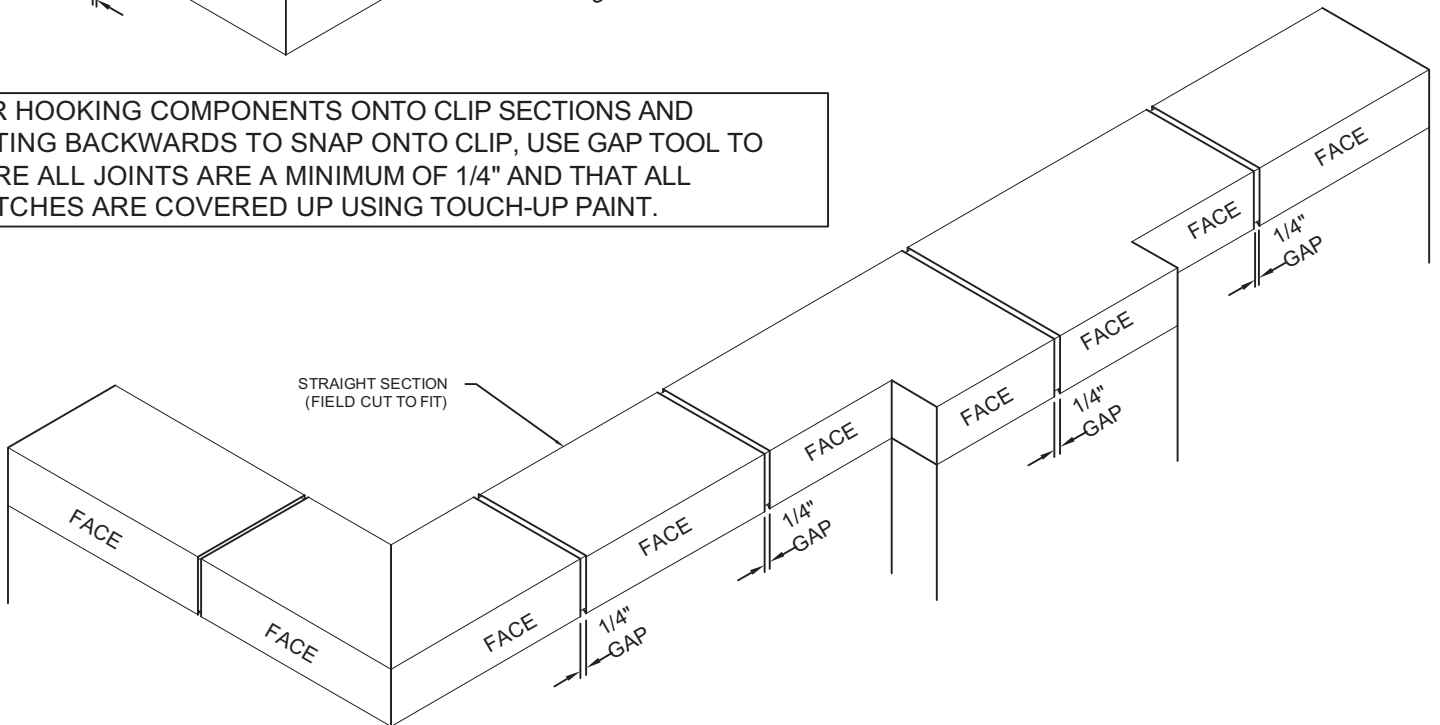

PIER MITER CONDITIONS

LOCATE OUTSIDE CORNER SUPPORT AT OUTSIDE PIER LOCATION FIRST.
PROCEED WITH LOCATING CENTER OF CLIP/SPLICES AT END OF EACH MITER LEG.
HOOK ONTO FRONT OF CORNER SUPPORT AND COPING CLIP, ROTATE BACKWARD ONTO CLIP AND
PUSH DOWNWARD TO ENGAGE CAP ONTO CLIP, THEN PROCEED WITH ADJACENT LEG.

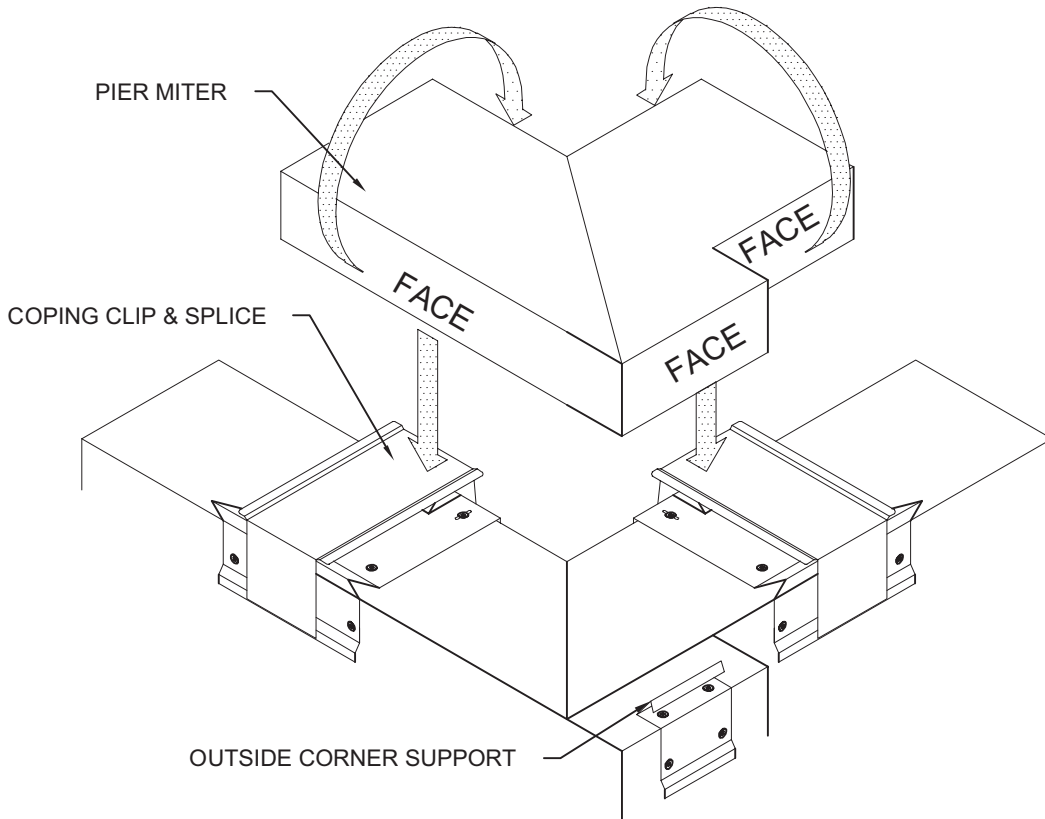

NOTE: ALL MITERS, END CONDITIONS, AND ACCESSORY CONDITIONS SHOULD BE INSTALLED PRIOR TO STRAIGHT SECTIONS

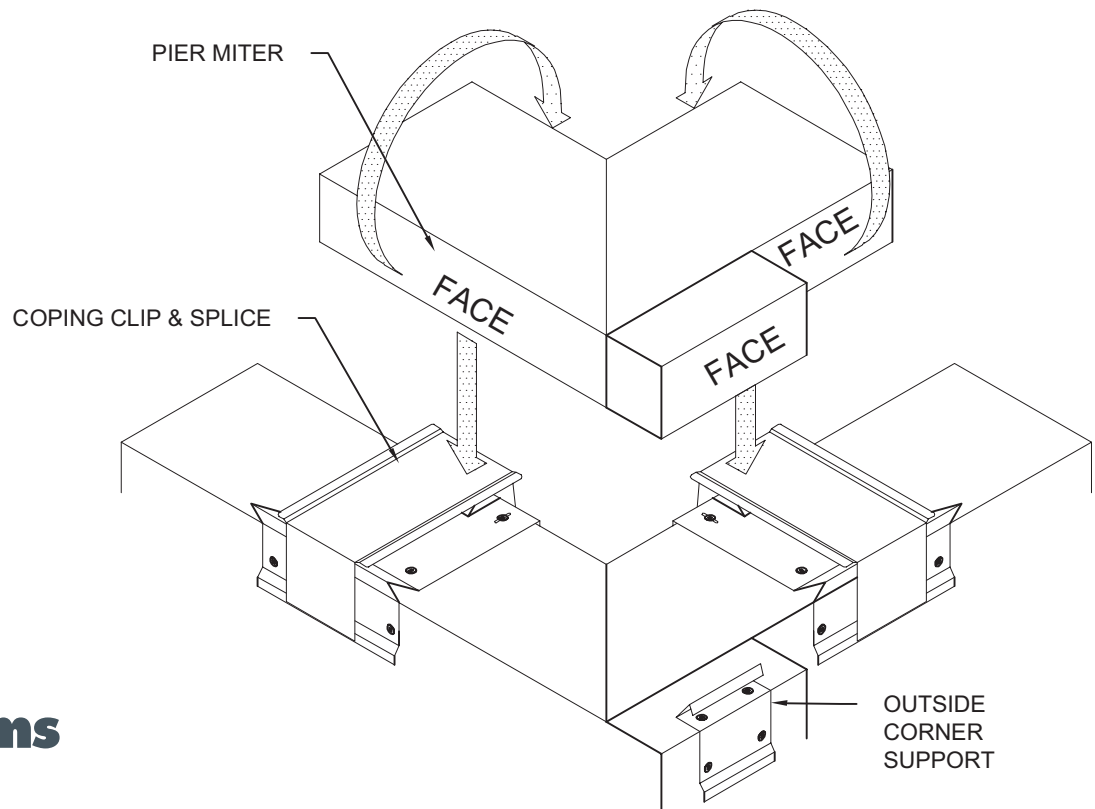

TEE MITER CONDITIONS

LOCATE CENTER OF CLIP/SPLICES AT END OF EACH MITER LEG.
HOOK ONTO FRONT OF COPING CLIPS WHICH ARE IN-LINE FIRST, ROTATE BACKWARD ONTO CLIP
AND PUSH DOWNWARD TO ENGAGE CAP ONTO CLIP, THEN PROCEED WITH ADJACENT LEG.

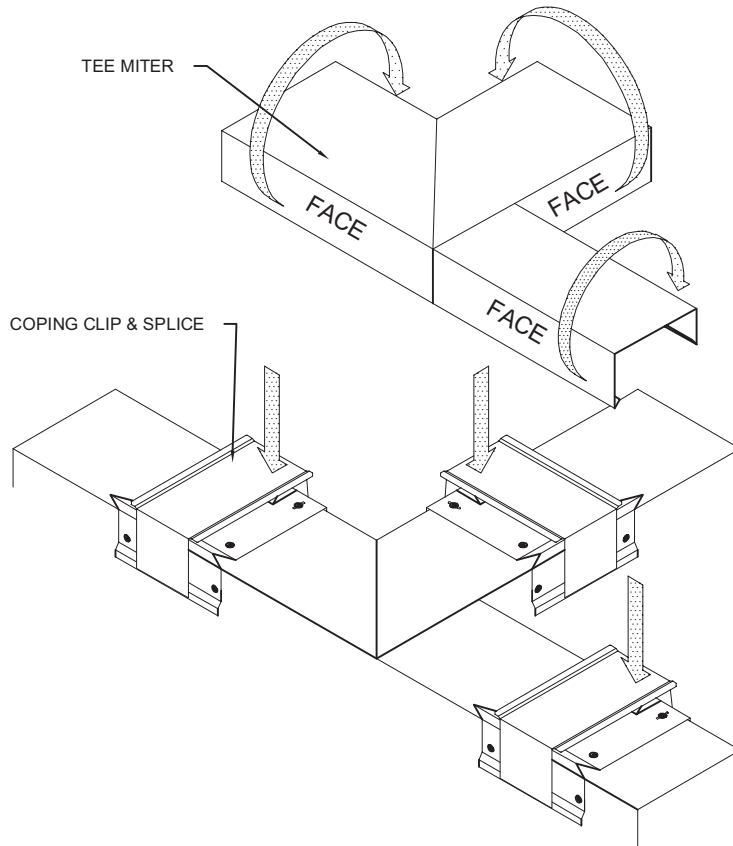

NOTE: ALL MITERS, END CONDITIONS, AND ACCESSORY CONDITIONS
SHOULD BE INSTALLED PRIOR TO STRAIGHT SECTIONS

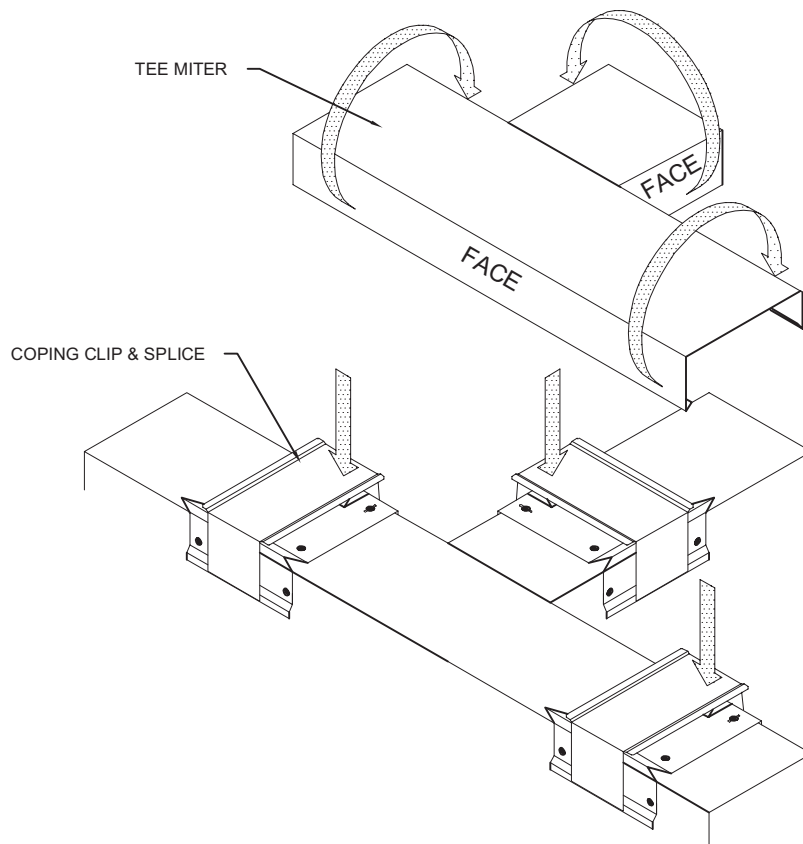

RIDGE MITER CONDITIONS & VALLEY MITER CONDITIONS

START INSTALLATION AT CORNER OR END CONDITIONS (SHOWN BELOW). LOCATE CLIPS AT END CONDITIONS AND SECURE TO SUBSTRATE AS SHOWN, BE SURE TO FOLLOW STEP 5 (PAGE 5) FOR INSTALLATION. FOR VALLEY MITERS, LOCATE CLIPS AT JOINTS (NO SPLICE REQUIRED FOR SLOPED WALLS AS SHOWN BELOW). LOCATE RIDGE MITER NEXT, BE SURE TO LOCATE CENTER OF CLIPS TO ALIGN WITH END OF RIDGE MITER (NO SPLICE REQUIRED FOR SLOPED WALLS AS SHOWN BELOW). ADJUST OFFSET CAP LENGTHS (DO NOT CUT FROM OFFSET TAB SIDE) TO FIT IN BETWEEN MITER AND END CONDITIONS ON SLOPED WALLS. USING SPACING CHART FOR CLIPS AS SHOWN BELOW.

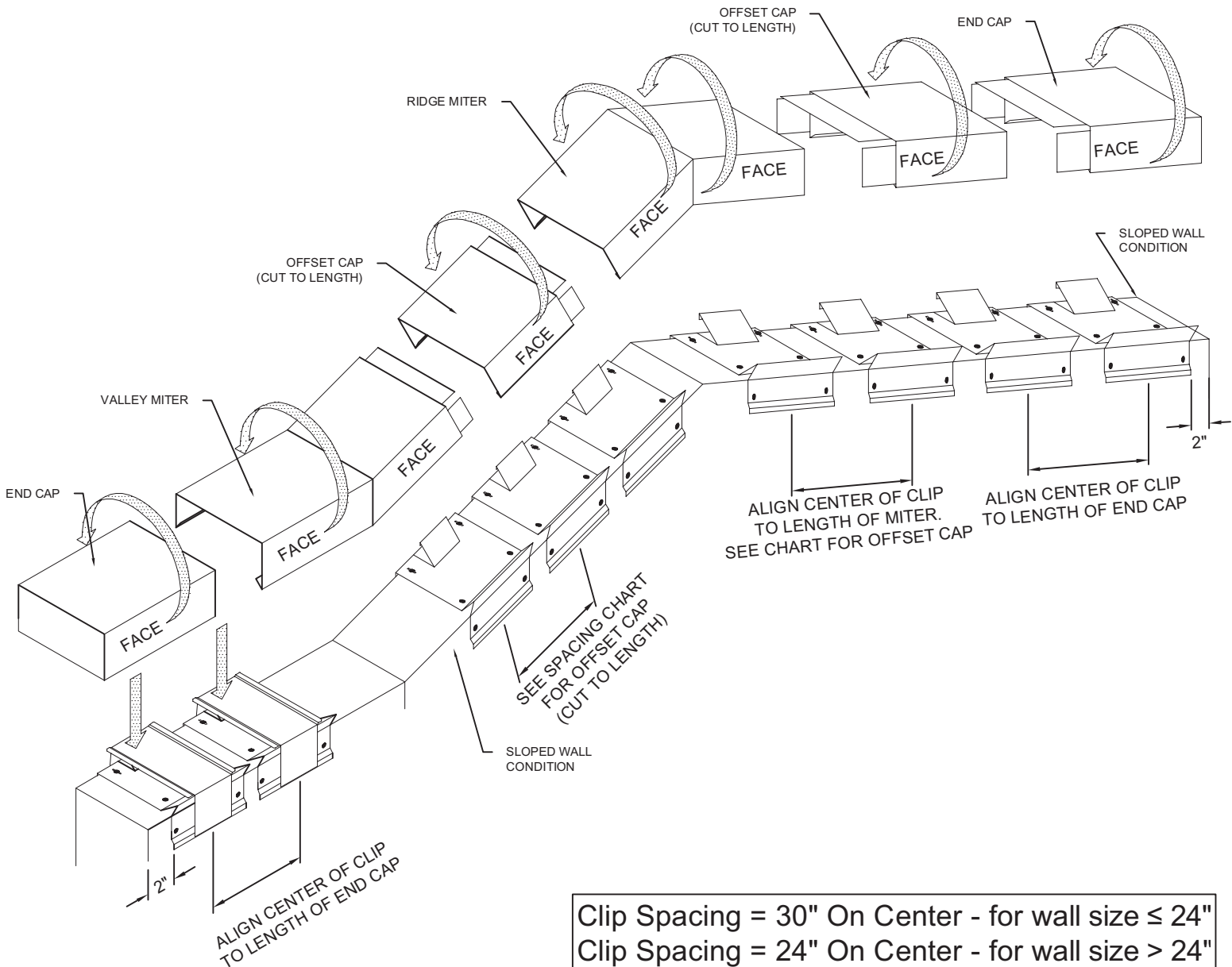

Clip Spacing = 30" On Center - for wall size $\leq 24"$
 Clip Spacing = 24" On Center - for wall size $> 24"$

HORIZONTAL ZEE MITER CONDITIONS

LOCATE CORNER SUPPORTS AT OUTSIDE AND INSIDE CORNER LOCATIONS FIRST.
NEXT LOCATE MIDDLE CLIP IN CENTER OF MIDDLE LEG OF ZEE MITER (IF SPACE ALLOWS).
PROCEED WITH LOCATING CENTER OF CLIP/SPLICES AT END OF EACH MITER LEG.
HOOK ONTO FRONT OF CORNER SUPPORT AND COPING CLIP, ROTATE BACKWARD ONTO CLIP AND
PUSH DOWNWARD TO ENGAGE CAP ONTO CLIP, THEN PROCEED WITH ADJACENT LEG.

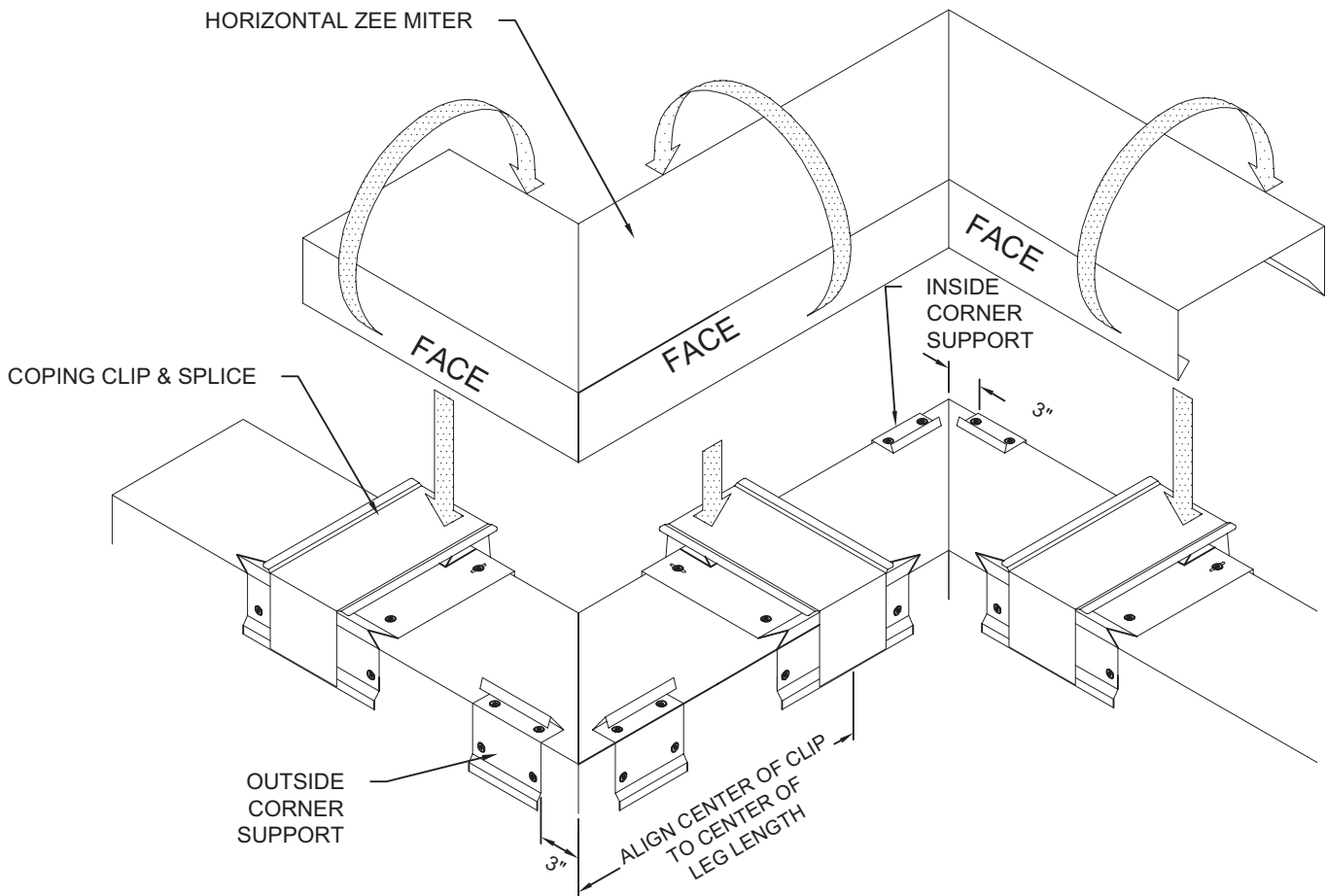

NOTE: ALL MITERS, END CONDITIONS, AND ACCESSORY CONDITIONS SHOULD BE INSTALLED PRIOR TO STRAIGHT SECTIONS

VERTICAL ZEE MITER CONDITIONS

LOCATE CENTER OF CLIP/SPLICES AT END OF EACH MITER LEG.
HOOK ONTO FRONT OF COPING CLIP, ROTATE BACKWARD ONTO CLIP AND PUSH
DOWNWARD TO ENGAGE CAP ONTO CLIP, THEN PROCEED WITH ADJACENT LEG.

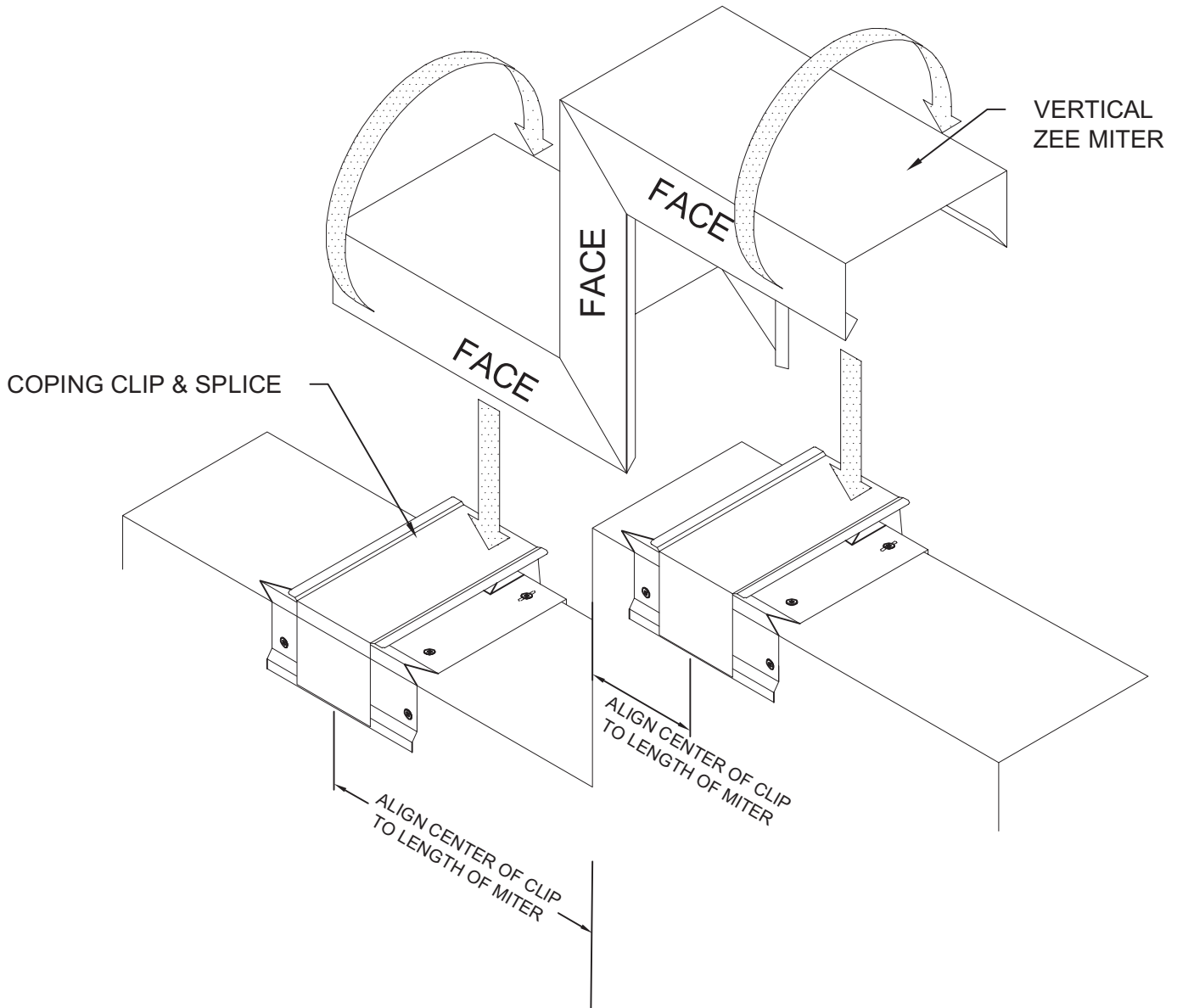

NOTE: ALL MITERS, END CONDITIONS, AND ACCESSORY CONDITIONS
SHOULD BE INSTALLED PRIOR TO STRAIGHT SECTIONS

RADIUS CONDITIONS

LOCATE CORNER SUPPORTS AT OUTSIDE AND INSIDE CORNER LOCATIONS FIRST. NEXT LOCATE CLIPS AT END LOCATIONS AS SHOWN IN STEP 5 (PAGE 5). PROCEED WITH LOCATING CENTER OF CLIP/SPLICES AT END OF EACH MITER LEG. HOOK ONTO FRONT OF CORNER SUPPORT AND COPING CLIP, ROTATE BACKWARD ONTO CLIP AND PUSH DOWNWARD TO ENGAGE CAP ONTO CLIP THEN PROCEED WITH ADJACENT LEG. FINALLY LOCATE ADDITIONAL CLIPS SPACED AT 20" ON CENTER FOR RADIUS SECTION (CUT AS NEEDED) SECURE CAP ONTO CLIPS BY PUSHING CAPS STRAIGHT DOWN SO THAT SPRINGS ALLOW FOR CAPS TO SECURE ONTO CLIPS.

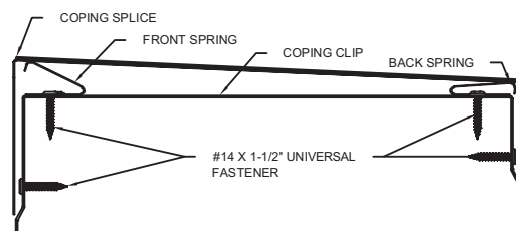
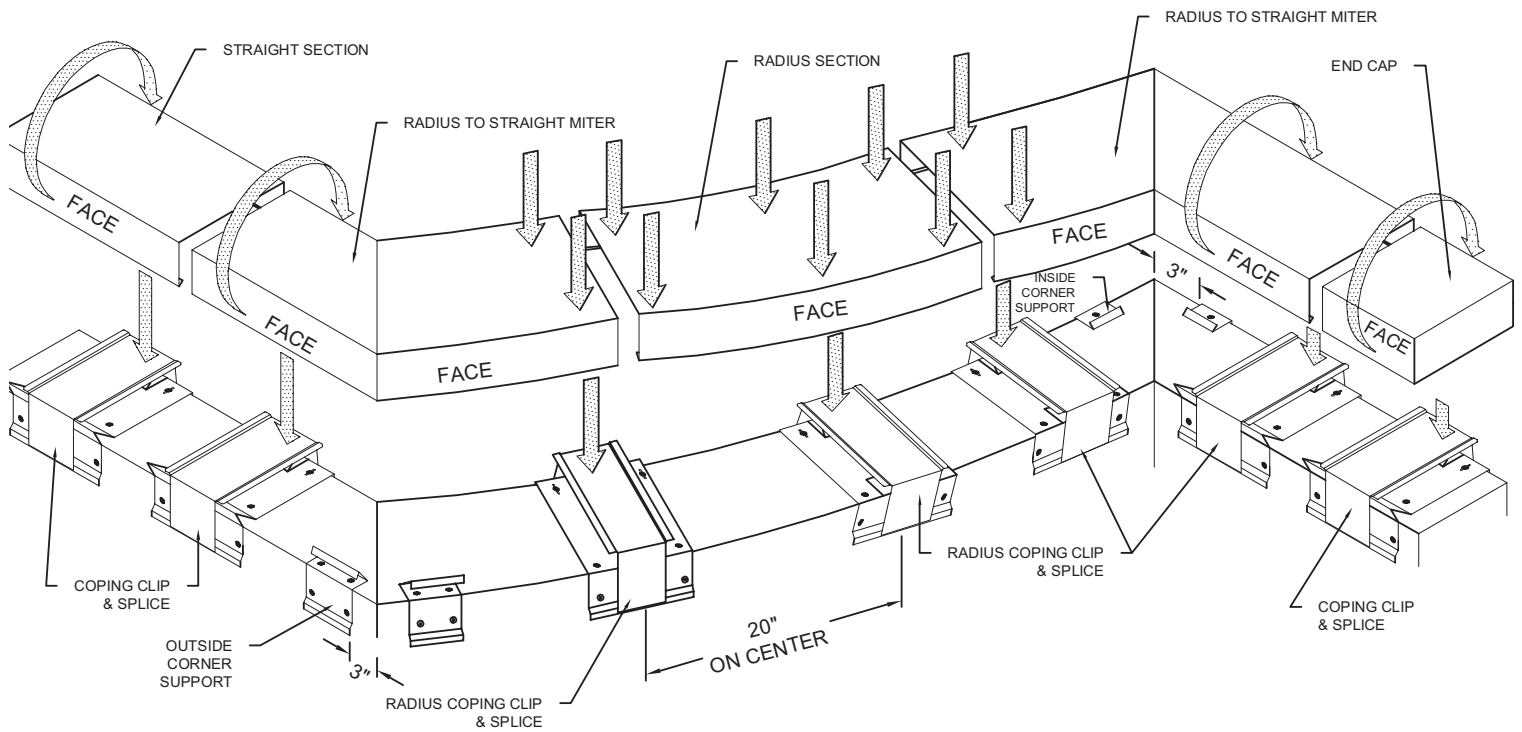

RADIUS CLIP/SPLICE PROFILE VIEW

NOTE: ALL MITERS, END CONDITIONS, AND ACCESSORY CONDITIONS SHOULD BE INSTALLED PRIOR TO STRAIGHT SECTIONS

VAULT CONDITIONS

LOCATE CENTER OF CLIPS AT END OF MITER LEGS FIRST. PROCEED WITH INSTALLING CLIPS PER STEP 5 (PAGE 5), HOOK CAP ROTATE BACKWARD ONTO CLIP AND PUSH DOWNWARD TO ENGAGE CAP ONTO CLIP. FINALLY LOCATE VAULT CLIPS AT 20" ON CENTER (NO SPLICES REQUIRED). SECURE CAP ONTO CLIPS BY PUSHING CAPS STRAIGHT DOWN SO THAT SPRINGS ALLOW FOR CAPS TO SECURE ONTO CLIPS. ADJUST VAULT CAP LENGTHS (DO NOT CUT FROM OFFSET TAB SIDE) TO FIT IN BETWEEN MITER AND END CONDITIONS ON SLOPED WALLS. USING SPACING CHART FOR CLIPS AS SHOWN BELOW.

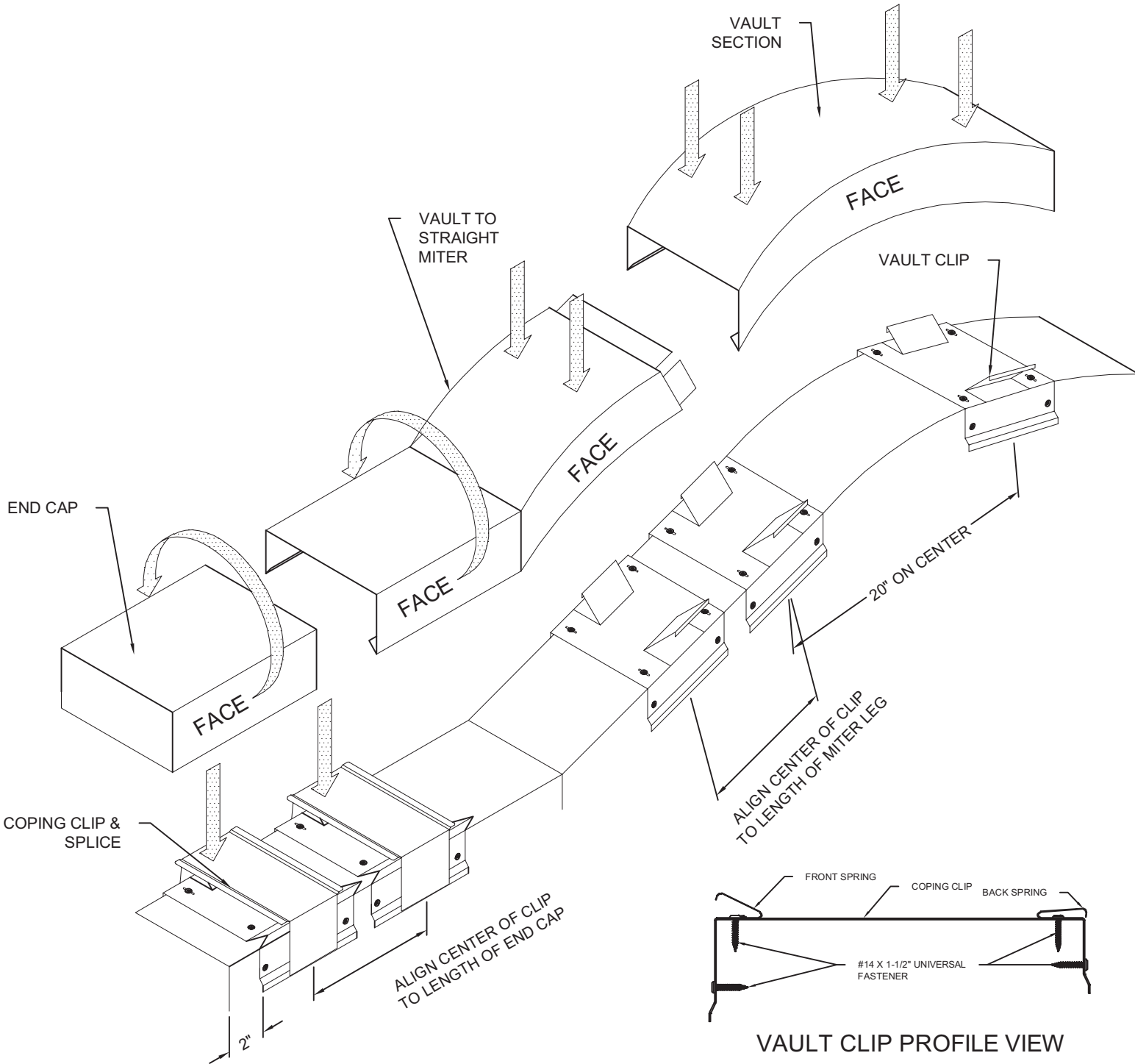

NOTE: ALL MITERS, END CONDITIONS, AND ACCESSORY CONDITIONS SHOULD BE INSTALLED PRIOR TO STRAIGHT SECTIONS



4 COMMERCE WAY, ARDEN, NC 28704 USA
800-892-9173 828-676-1700 OMGEDGESYSTEMS.COM

Copyright © 2020 OMG, Inc. All rights reserved.

Superior productivity.
Superior performance.

